



## Model Number

EVM58-IZ

## Features

- Industrial standard housing Ø58 mm
- EtherNet/IP
- Up to 30 Bit multiturn
- Servo or clamping flange
- Network loop through by means of integrated 2 port switch
- IP address resettable
- No DIP switches for address setting
- Compatible with Rockwell/ Allen Bradley/ Schneider control
- Mechanical compatibility with all major encoders with fieldbus interface
- Rotary axis functionality
- Status LEDs
- Ethernet IP declaration of conformity
- CIP encoder profile

## Description

In addition to the CANopen-, DeviceNet-, PRO-FIBUS- and AS-Interface encoders, we have broadened our product line of bus-capable absolute encoders with the EVM58 for Ethernet.

Absolute multiturn rotary encoders deliver an absolute step value for each angle setting.

This device has a maximum basic resolution of 65536 steps per revolution (16 bits) and codes up to 16384 revolutions (14 bits). Thus the overall resolution amounts to 30 bits. On account of the high number of measuring steps resulting (more than 1 billion), this type of encoder can be used to divide very long linear distances into small measuring steps.

The device is designed for shaft assembly and is available in servo flange or clamping flange design.

## Technical data

### General specifications

Detection type	photoelectric sampling
Device type	Multiturn absolute encoder

### Functional safety related parameters

MTTF <sub>d</sub>	120 a
Mission Time (T <sub>M</sub> )	20 a
L <sub>10h</sub>	1.9 E+11 at 6000 rpm and 20/40 N axial/radial shaft load
Diagnostic Coverage (DC)	0 %

### Electrical specifications

Operating voltage U <sub>B</sub>	10 ... 30 V DC
Power consumption P <sub>0</sub>	max. 4 W
Linearity	± 0.5 LSB (12 Bit) ,
Output code	binary code
Code course (counting direction)	programmable, cw ascending (clockwise rotation, code course ascending) cw descending (clockwise rotation, code course descending)

### Interface

Interface type	EtherNet/IP
Resolution	
Single turn	up to 16 Bit
Multiturn	14 Bit
Overall resolution	up to 30 Bit
Physical	Ethernet
Transfer rate	100 MBit/s

### Connection

Connector	Ethernet: 2 sockets M12 x 1, 4-pin, D-coded Supply: 1 plug M12 x 1, 4-pin, A-coded
-----------	---

### Standard conformity

Degree of protection	DIN EN 60529, shaft side: IP64 (without shaft seal)/IP66 (with shaft seal) housing side: IP65 Stainless steel version (INOX): completely IP67
Climatic testing	DIN EN 60068-2-3, no moisture condensation
Emitted interference	EN 61000-6-4:2007
Noise immunity	EN 61000-6-2:2005
Shock resistance	DIN EN 60068-2-27, 100 g, 6 ms
Vibration resistance	DIN EN 60068-2-6, 10 g, 10 ... 2000 Hz

### Ambient conditions

Operating temperature	-40 ... 85 °C (-40 ... 185 °F)
Storage temperature	-40 ... 85 °C (-40 ... 185 °F)

### Mechanical specifications

Material	housing: powder coated aluminum flange: aluminum shaft: stainless steel
Combination 1	housing: powder coated aluminum flange: aluminum shaft: stainless steel
Combination 2 (Inox)	housing: stainless steel 1.4305 / AISI 303 flange: stainless steel 1.4301 / AISI 304 shaft: stainless steel 1.4305 / AISI 303
Mass	approx. 370 g (combination 1) approx. 840 g (combination 2)
Rotational speed	max. 12000 min <sup>-1</sup>
Moment of inertia	30 gcm <sup>2</sup>
Starting torque	≤ 3 Ncm (version without shaft seal)
Shaft load	
Axial	40 N
Radial	110 N

### Approvals and certificates

UL approval	cULus Listed, General Purpose, Class 2 Power Source
-------------	---

Dimensions

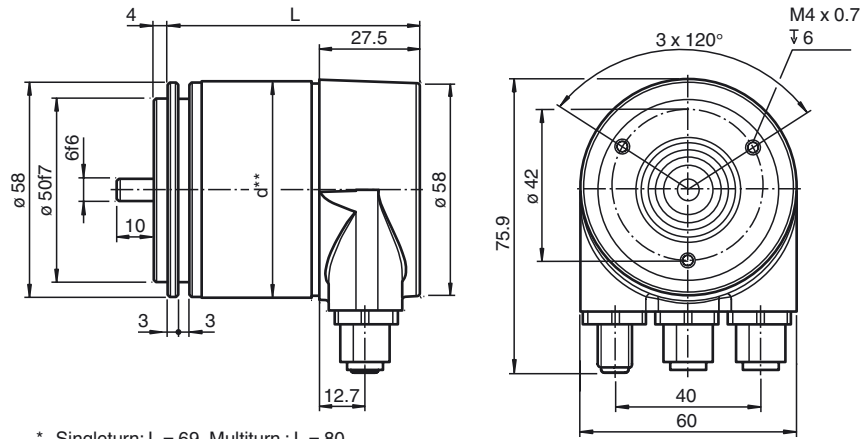

\* Singleturn: L = 69, Multiturn : L = 80  
 \*\* Aluminum: d = 59, stainless steel: d = 61

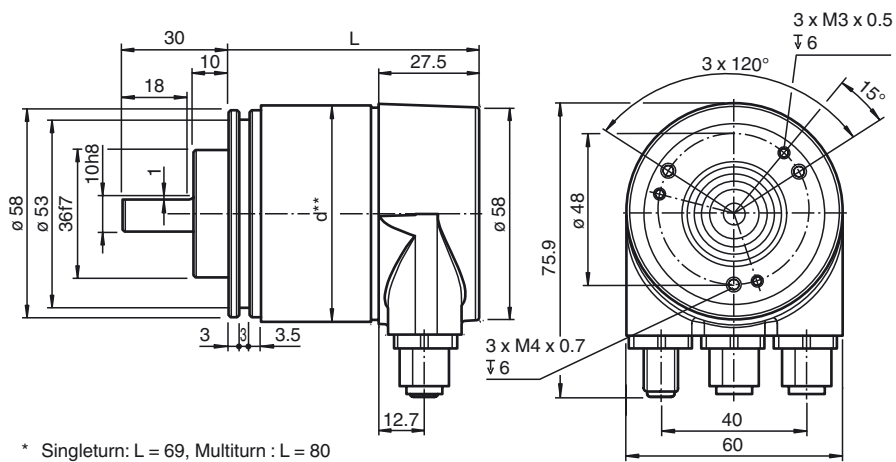

\* Singleturn: L = 69, Multiturn : L = 80  
 \*\* Aluminum: d = 59, stainless steel: d = 61

**Electrical connection**

Pin	Male connector M12 x 1, 4-pin, A-coded	Female connector M12 x 1, 4-pin, D-coded
1	Supply voltage +U <sub>B</sub>	Tx +
2	-	Rx +
3	0 V	Tx -
4	-	Rx -

	
---	--

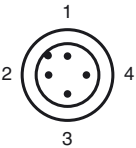
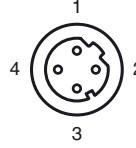
**Indicators**

**Diagnostic LEDs**

LED	Color	Description for LED = ON
Active1	Yellow	Incoming and outgoing data traffic for port 1
Link1*	Green	Connection to other Ethernet devices on port 1
Active2	Yellow	Incoming and outgoing data traffic for port 2
Link2*	Green	Connection to other Ethernet devices on port 2
Stat1	Green	Status 1, details see table below
Stat2	Red	Status 2, details see table below

\* flashes with 2 Hz if engineering identification call is activated and link connection is available

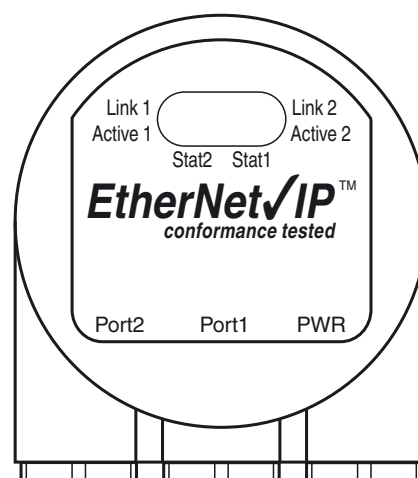

Stat1 (green)	Stat2 (red) bus failure	Meaning	Cause
off	off	No power	
on	on	No connection to another device Criteria: no data exchange	<ul style="list-style-type: none"> <li>• bus disconnected</li> <li>• Master not available / switched off</li> </ul>
on	flashes <sup>1)</sup>	Parameterization fault, no data exchange Criteria: data exchange correct. However, the slave did not switch to the data exchange mode.	<ul style="list-style-type: none"> <li>• Slave not configured yet or wrong configuration</li> <li>• Wrong station address assigned (but not outside the permitted range)</li> <li>• Actual configuration of the slave differs from the nominal configuration</li> </ul>
on	off	Data exchange. Slave and operation ok.	

1) flashing frequency 0.5 Hz for at least 3 seconds

Release date: 2016-02-02 11:12 Date of issue: 2016-02-02 t43991\_eng.xml

## Accessories

Accessories	Name/defining feature	Order code	Description
Couplings	D1: Ø6 mm, D2: Ø6 mm	9401	shaft Ø6 mm
	D1: Ø6 mm, D2: Ø6 mm	9402	
	D1: Ø6 mm, D2: Ø6 mm	9404	
	D1: Ø6 mm, D2: Ø6 mm	9409	
	D1: Ø6 mm, D2: Ø6 mm	KW	shaft Ø10 mm
	D1: Ø10 mm, D2: Ø10 mm	9401	
	D1: Ø10 mm, D2: Ø10 mm	9404	
	D1: Ø10 mm, D2: Ø10 mm	9409	
Measurement wheels with circumference of 500 mm	Plastic	9101, 10	shaft Ø10 mm
	Pimpled rubber	9102, 10	
	Knurled aluminium	9103, 10	
	Knurled plastic	9112, 10	
Measurement wheels with circumference of 200 mm	Plastic	9108, 10	shaft Ø10 mm
	Pimpled rubber	9109, 10	
	Knurled aluminium	9110, 10	
	Knurled plastic	9113, 10	
Mounting aids	Mounting bracket	9203	Clamping flange
	Mounting bracket	9213	
Mounting aids	Mounting bracket and set	9300 and 9311-3	Servo flange
	Eccentric clamping elements	9310-3	

For additional information on the accessories, please see the "Accessories" section.

Order code

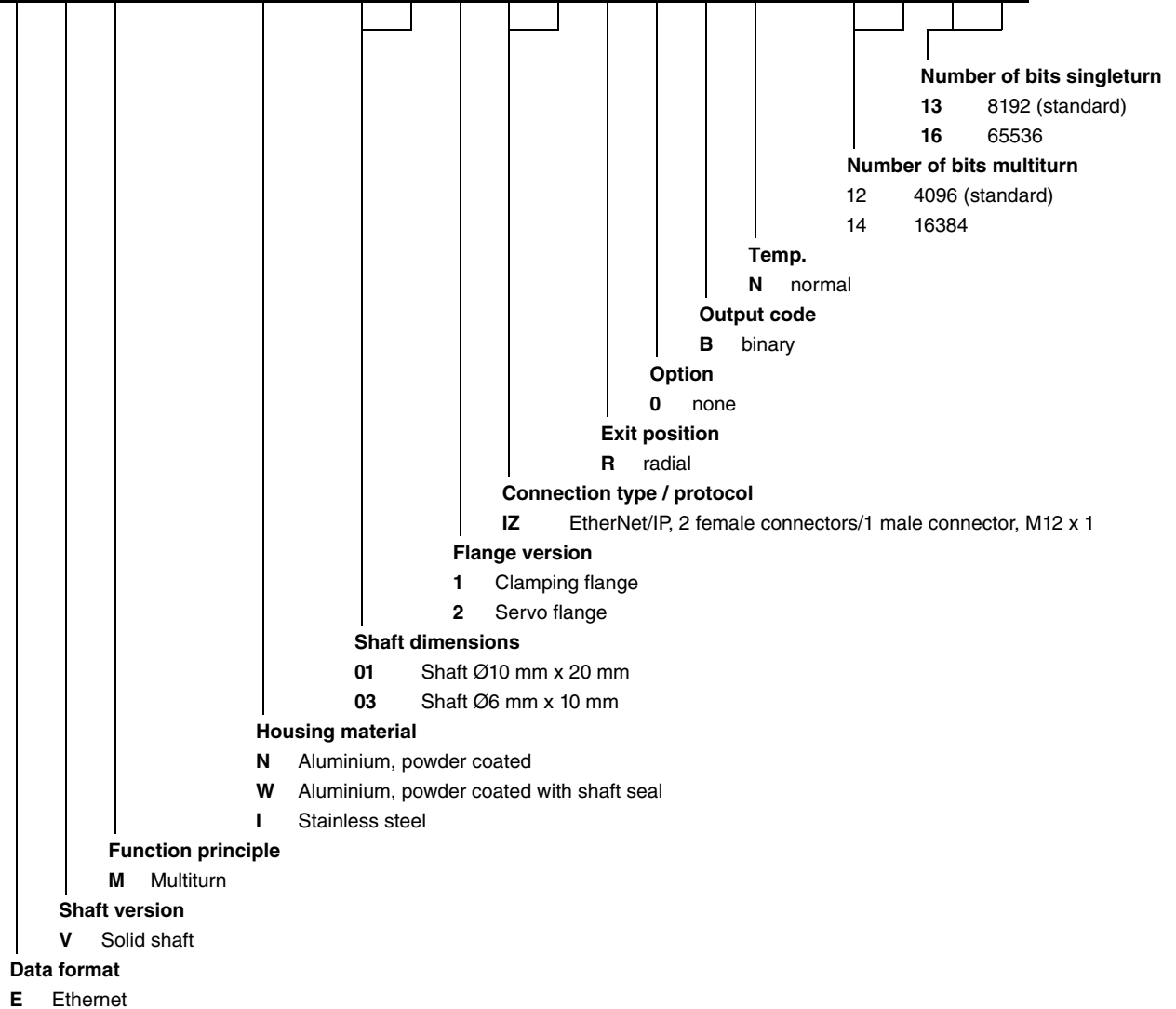

Release date: 2016-02-02 11:12 Date of issue: 2016-02-02 t43991\_eng.xml